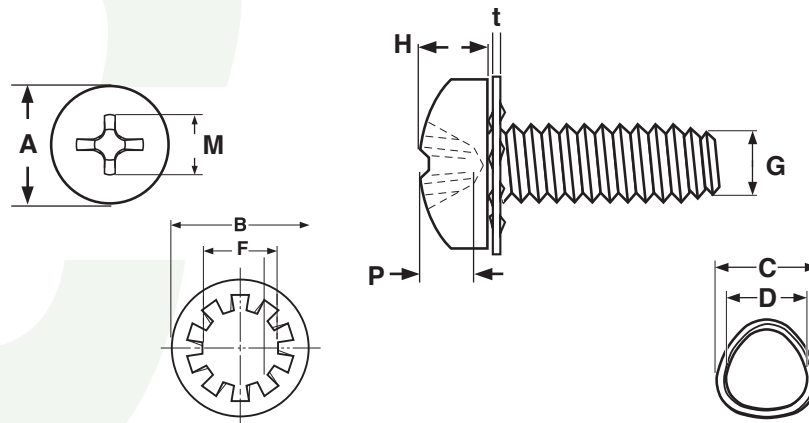

SELF-TAPPING SCREWS

THREAD ROLLING

Trilobular Pan
Internal Tooth SEMS

TRILOBULAR THREAD ROLLING SCREW INTERNAL TOOTH SEMS, PAN PHILLIPS

| Nominal Screw Size & Threads per Inch | A | | H | | B | | F | | t | | C | | D | | G | M | P | | Phillips Driver Size |
|---|------------------|------|-------------|------|---------------------------|------|--------------------------|------|---------------------------------|------|------------------------------------|------|------------------------------|------|---|----------------|----------------------|------|----------------------------|
| | Head Diameter | | Head Height | | Washer Outside Diam | | Washer Inside Diam | | Washer Material Thickness | | Circumscrib- ing Circle Diam | | Measurement Across Center | | Point Diam of Circum- scribing Circle | Drive Diam. | Gauge Penetration | | |
| | Max | Min | Max | Min | Max | Min | Max | Min | Max | Min | Max | Min | Max | Min | Max | Ref | Max | Min | |
| 4-40 | .219 | .204 | .080 | .069 | .268 | .257 | .104 | .100 | .018 | .012 | .114 | .110 | .110 | .105 | .090 | .115 | .071 | .053 | 1 |
| 6-32 | .270 | .255 | .097 | .086 | .288 | .277 | .126 | .123 | .022 | .016 | .141 | .134 | .135 | .128 | .111 | .159 | .080 | .055 | 2 |
| 8-32 | .321 | .305 | .115 | .104 | .338 | .326 | - | - | .023 | .018 | .167 | .160 | .161 | .154 | .137 | .177 | .097 | .071 | 2 |
| 10-24 | .372 | .356 | .133 | .121 | .382 | .371 | - | - | .023 | .018 | .194 | .187 | .185 | .178 | .152 | .193 | .113 | .089 | 2 |
| 10-32 | .372 | .356 | .133 | .121 | .382 | .371 | - | - | .023 | .018 | .193 | .186 | .187 | .180 | .163 | .193 | .113 | .089 | 2 |
| Tolerance on Length | | | | | | | | | + 0, -0.03 | | | | | | | | | | |

| | | |
|--|--|--|
| Description | Trilobular thread rolling screw with a gently rounded top surface and a captive, free-spinning internal tooth lockwasher manufactured as one assembly. As each lobe of the screw moves through the pilot hole in the nut material, it forms and work-hardens the nut thread metal, producing an uninterrupted grain flow. | |
| Applications/ Advantages | For drilled, punched or corrod holes in all ductile metals and punch extruded metals. Eliminates chips, requires low drive torque and provides excellent resistance to vibrational loosening. The washer/screw assembly makes this a locking screw with the washer providing the locking action. Machine pre-assembly provides cost savings to the end user. | |
| Material | Screw 1022 or equivalent carbon steel | Washer 1050 or equivalent spring steel |
| Heat Treatment | Screws shall be quenched in liquid and then tempered by reheating to 650°F minimum. | |
| Case Hardness | Rockwell C45 minimum | |
| Case Depth | 2-56 through 6-32 diameters: .002 - .007 8-32 through 10-32 diameters: .004 - .009 | |
| Core Hardness (after tempering) | Rockwell C28-38 | Rockwell C40 - 50 |
| Plating | See Appendix-A for information on the plating of trilobular thread rolling SEMS screws. | |