

SELF- TAPPING SCREWS

#5 Point with neo-EPDM Washer
SPACED Thread

SELF-DRILLING

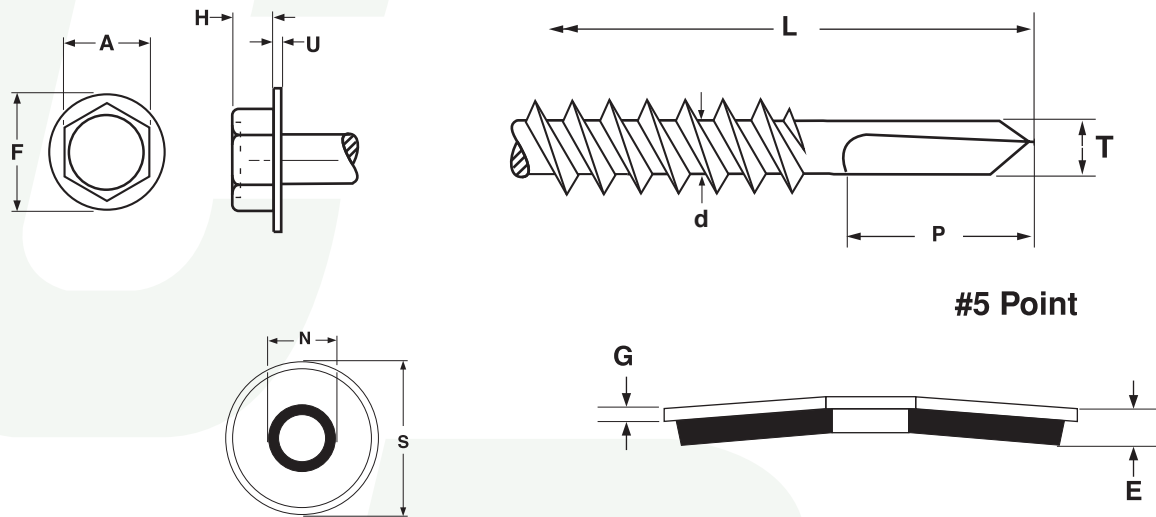

#5 Point

#5 DRILL POINT HEX WASHER SELF-DRILLING SCREW W/ NEO-EPDM WASHER																	
Nominal Size	Threads Per Inch	D		d		P		T		A		F		H		U	
		Major Diameter		Minor Diameter		Point Length		Point Diameter		Width Across Flats		Washer Diameter		Head Height		Washer Thickness	
		Max	Min	Max	Min	Max	Min	Max	Min	Max	Min	Max	Min	Max	Min	Max	Min
12	14	0.215	0.208	0.165	0.156	0.630	0.571	0.193	0.185	0.312	0.304	0.432	0.397	0.194	0.160	0.039	0.022

NEO-EPDM WASHERS USED WITH SELF PIERCING & SELF DRILLING SCREWS								
For Use with Screw of this Nominal Diameter	S		N		G		E	
	Outside Diameter of Steel Section		Inside Diameter of Steel Section		Thickness of Steel Section		Total Thickness (EPDM & Steel)	
	Max	Min	Max	Min	Max	Min	Max	Min
12	.558	.542	.243	.227	.039	.023	.125	.093

Description	A tapping screw with an integrally formed hex washer head, spaced threads, and a drill point significantly longer than that of a # 2 or #3 point drill screw. Beneath the head is a thin conically-shaped circular steel washer, bonded to a similarly shaped rubber-like piece which as a slightly smaller outside and inside diameter. When these washers are assembled (rubber side down) to self-piercing or self-drilling screws, those fasteners become "sealing screws".
Applications/ Advantages	Designed to drill through a greater thickness of steel than a standard self drilling screw. Although it can assist in attaching metal deck to structural steel, the #5 point self drilling screws are not structural bolts and should not be used as such. The neo-EPDM washer: (a) offers protection against leakage; (b) provides load bearing qualities superior to that of a regular flat washer; (c) reduces the chance of the fastening becoming loose due to vibration; (d) minimizes damage to the mating surface caused by contact with a steel washer.
Material	<i>Screw:</i> AISI 1016-1024 or equivalent steel; <i>Steel Section of washer:</i> 20 gauge steel; <i>Elastic Section of washer:</i> Style 40 EPDM sheet
Heat Treatment	Screws shall be quenched in liquid and then tempered by reheating to 625°F minimum.
Case Hardness	<i>Screw:</i> Rockwell C52 -58
Case Depth	<i>No. 12 diameter:</i> .004 - .009
Core Hardness (after tempering)	<i>Screw:</i> Rockwell C32 - 40 <i>Material:</i> Shore A 65 - 75 (Durometer scale)
Plating	See Appendix-A for plating information.