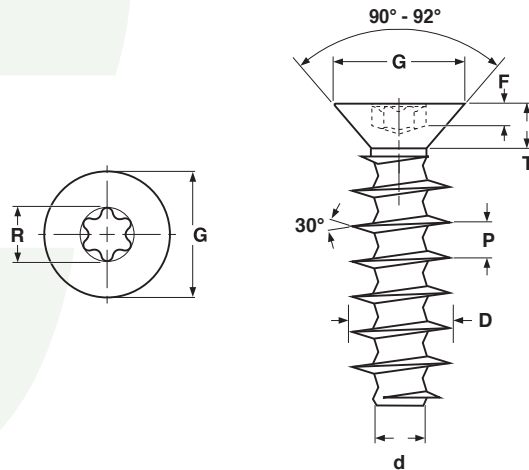

## METRIC FASTENERS

## THREAD FORMING SCREWS

Type-PT® Alternative  
Flat Six-Lobe

## METRIC - TYPE PT®-ALTERNATIVE THREAD FORMING SCREWS, FLAT 6-LOBE

Screw Size	P	D		d	G		T	R	F	Drive Size	
	Thread Dimensions				Head Dimensions			Recess Dimensions			
	Thread Pitch	External Thread Diam.		Thread Core	Diameter		Height	Diameter	Gauge Penetration		
	Ref	Max	Min	Ref	Max	Min	Ref	Max	Min		
M1.6	0.67	1.74	1.60	0.92	3.30	2.90	0.96	1.47	0.50	T5	
M2	0.89	2.14	2.00	1.15	3.80	3.53	-	1.75	0.50	T6	
M2.2	0.98	2.34	2.20	1.25	3.80	3.53	1.20	1.75	0.70	T6	
M2.5	1.12	2.64	2.50	1.40	4.70	4.43	1.70	2.40	0.80	T8	
M3	1.34	3.14	3.00	1.66	5.50	5.23	1.80	2.40	0.80	T8	
M3.5	1.57	3.68	3.50	1.91	7.30	6.97	2.50	3.35	1.00	T15	
M4	1.79	4.18	4.00	2.17	8.40	8.07	2.90	3.95	1.25	T20	
M5	2.24	5.18	5.00	2.68	9.30	8.97	-	3.95	1.25	T20	
Tolerance on Length				3 ~ 6mm: ± 0.375 mm				7 ~ 10mm: ± 0.45 mm			
				11 ~ 30mm: ± 0.50 mm				31 ~ 80mm: ± 0.65 mm			

• NOTE: Dimensions for the M1.6 nominal diameter are independent of the EJOT® Type-PT® standard.

<b>Description</b>	A spaced thread fastener with a countersunk head, having a flat top surface and a cone-shaped bearing surface with a head angle of approximately 90°. When compared to a Plastite®-alternative thread rolling screw, the PT®-alternative threads are wider and have a sharper angle. Furthermore, the core of the shank has a reduced diameter between each consecutive set of threads. The point opposite the head is blunt.	
<b>Applications/ Advantages</b>	Designed to form its own thread in thermoplastic materials. The 30° thread angle reduces the outward expansion of the material being displaced. The recessed design of the thread root enables more material to flow into the area between threads. The depth of the thread pattern increases the fastener's load carrying properties while resisting vibrations, thus resisting loosening.	
<b>Material</b>	<b>Steel</b> Diameter M3 & smaller: Case-Hardened C1022 Steel Diameters M3.5 and larger: Through-hardened C1022 Steel	<b>Stainless</b> A2 Stainless Steel
<b>Core Hardness</b>	HV 270 - 390	-
<b>Surface Hardness</b>	HV 450 min.	-

Type PT® is a registered trademark of EJOT Verbindungstechnik GmbH & Co. KG.