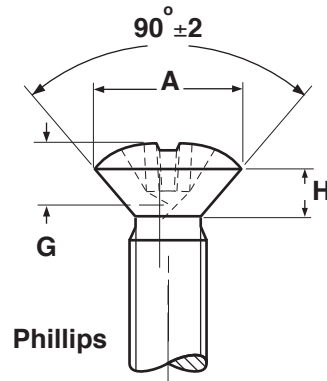

METRIC FASTENERS

MACHINE SCREWS

DIN 966
Oval Head

METRIC - PHILLIPS OVAL HEADS FOR MACHINE SCREWS							DIN 966
Nominal Size	Thread Pitch	A		H	G		Phillips Driver Size
		Head Diameter		Head Side Height	Recess Penetration		
		Max	Min	Max	Max	Min	
M1.6	0.35	3.00	2.86	0.96	1.10	0.74	0
M2	0.4	3.8	3.5	1.2	1.40	1.10	1
M2.5	0.45	4.7	4.4	1.5	1.60	1.30	1
M3	0.5	5.6	5.3	1.65	2.00	1.70	1
M4	0.7	7.50	7.14	2.2	2.54	2.04	2
M5	0.8	9.20	8.84	2.5	3.27	2.77	2
M6	1	11.00	10.57	3	3.53	3.03	3
M8	1.25	14.50	14.07	4	4.68	4.18	4
M10	1.5	18.00	17.57	5	5.88	5.38	4